

HOT & COLD BUFFER TANK - DN20

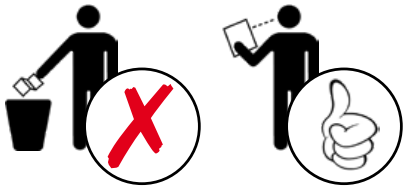

Schematics: buffer tank installed horizontally

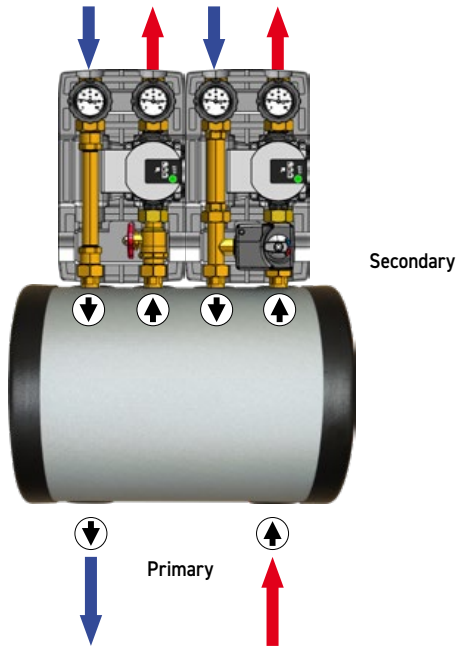

A+

Schematics: buffer tank installed vertically

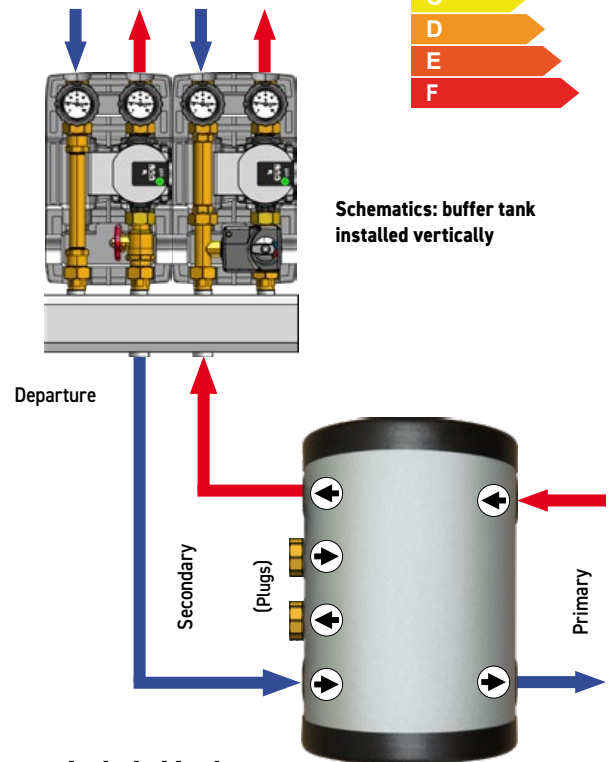

Plugs not included in the delivery of the article.

Dimensions

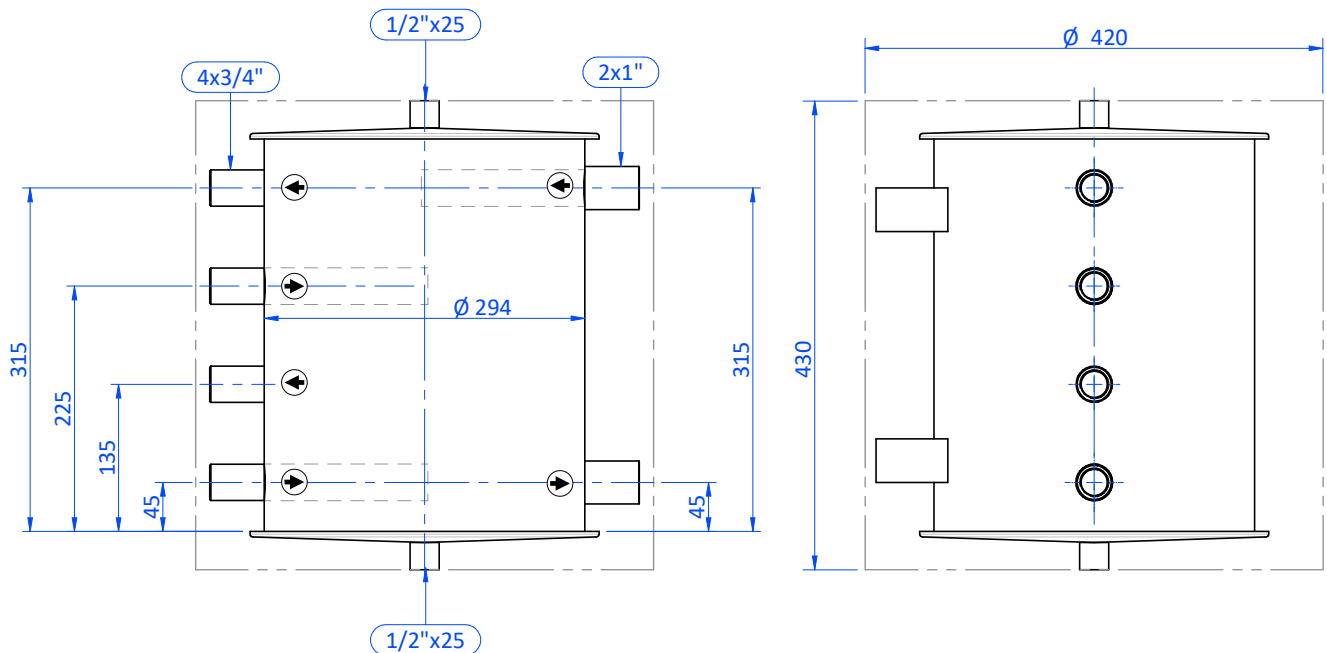

Code	Primary connection	Secondary connection	Pump unit / center distance	Capacity	Working pressure	Max. working temperature	Min. working temperature	Pressure test
HWDN20/90-25	G 1" F	G 3/4" F	DN20 - 90 mm	25 L	6 bar	90°C	-10°C	9 bar

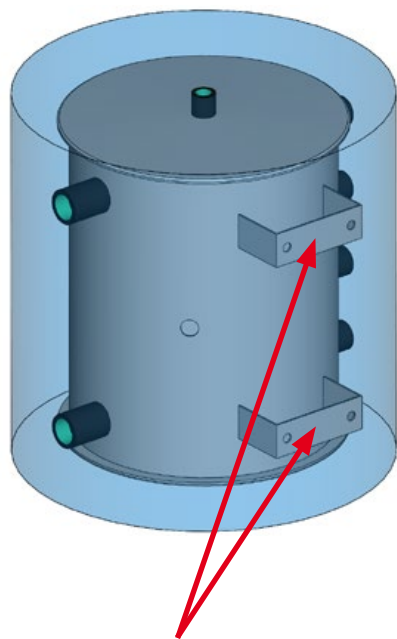

**Wall mounting bracket
included in the delivery of
the article.**

