

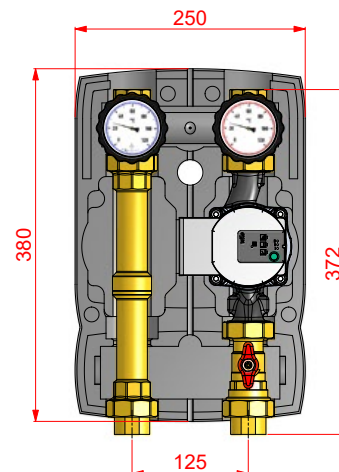

Installation instructions

DIMENSIONS

EPP insulation box: the insulation covering includes a central inside part that hugs the circulating pump and that allows the passage of the cable of the circulating pump. Outlets for the passage of the cables towards the upper part and the lower part of the insulation box. *Dimensions: 250x380x170 mm.*

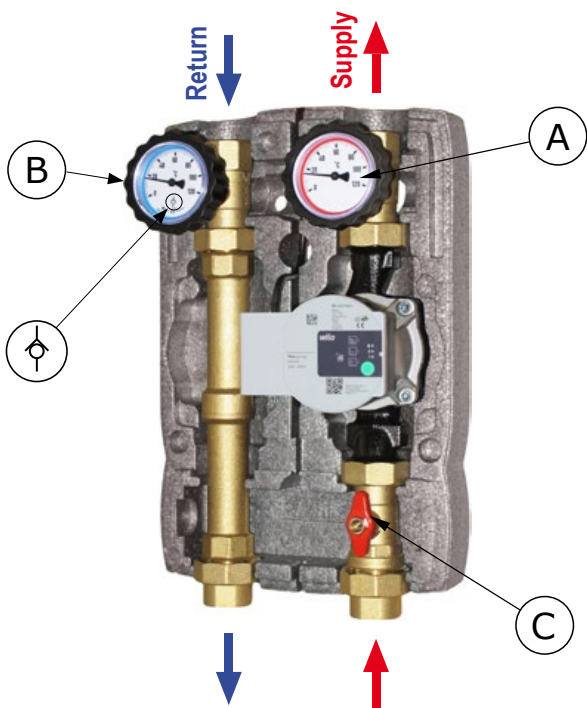

SERVICE

To operate an incidental service or replacement of the circulating pump, close the ball valve (A) and (C) by rotating the relevant handles clockwise. Once the service is over, open again the two ball valves and restore the pressure of the installation.

TECHNICAL FEATURES

PN 10. Maximum temperature 110°C (calculated with pump unit without circulating pump)

Available external connections: 1" F

20 mbar CHECK VALVE

It is always inside the ball valve (B) of the return way, it prevents the natural circulation of the fluid (thermosiphon effect). The check valve can be excluded by rotating the handle by 45° clockwise from the opening position.



FIELD OF USE

For power up to 50 kW (with Δt 20 K) and maximum flow 2150 l/h. Kvs Value: 8.0.

Approximate data calculated with a 6 m head circulating pump. For an accurate measuring or for higher flows, please refer to the curve of the circulating pump.

INVERSION OF THE PUMP UNIT. LEFT SUPPLY.

All M2 pump units can be inverted to change the supply way from right side (the most popular execution) to the left side.

Right supply

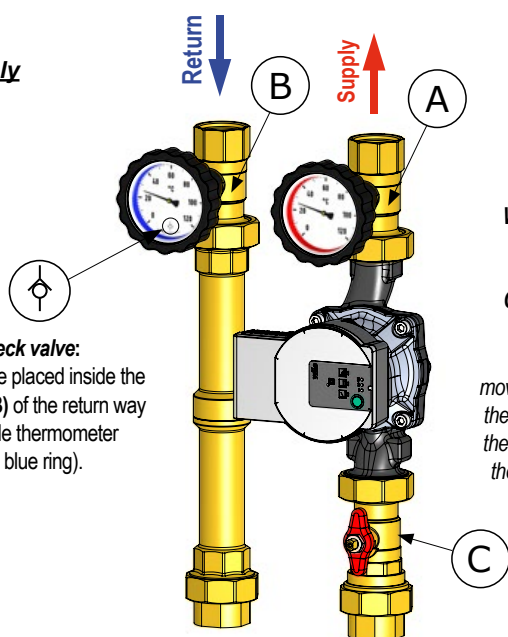

Check valve:
Always to be placed inside the ball valve (B) of the return way (in-handle thermometer with blue ring).

INVERT THE RIGHT WAY WITH THE LEFT WAY AND ROTATE THE MOTOR OF CIRCULATING PUMP

Circulating pump:
move the circulating pump to the opposite way and rotate the motor by 180° (unscrew the special screws, rotate, screw again)

Left supply

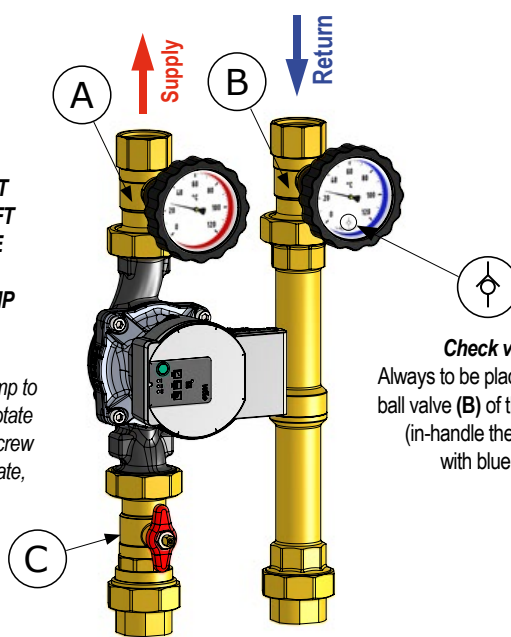

Check valve:
Always to be placed inside the ball valve (B) of the return way (in-handle thermometer with blue ring).

- (A) Ball valve on the supply way (in-handle thermometer with red ring)
- (B) Ball valve on the return way (in-handle thermometer with blue ring) with check valve

For the setting and for the possible inversion of the overpressure balancing by-pass, available in the M3 model pump units, please refer to the specific instructions sheet.