

MCCS 3 - DN25 ANTI-CONDENSING RECYCLING PUMP UNIT

Directions for installation



SAFETY: Please read carefully the mounting and setting up directions before setting the system going, in order to avoid accidents and failures of the installation caused by an improper use of the product. Please look it up in the servomotor manual too. Keep this manual for future consultations.

List and basic technical features of the main components

(A) Circulating pump.
Synchronous high efficiency Wilo Para STG/8 circulating pump. The label on the circulating pump shows the standard hydraulic scheme and the features of the model.

(B) Thermometers.
Thermometers showing the temperature, with scale 0-120°C. They can be moved to the opposite side of the body, in accordance to the orientation of the pump unit in the installation.

(C) Isolating ball valve.
Isolating ball valve mounted on the three connections. Operating system with allen screw.

(D) Servomotor.
Fixed temperature servomotor with electronic control of return temperature. Adjustable target temperature setting from 10°C up to 90°C. Visualization of measured and target temperature on LCD display. Otherwise 3 points servomotor: in this case an outside electronic control is required.

(E) Operating rod.
External control rod of the internal clapet valve. It can be kept working or not working according to the installation specifications.

(F) Temperature sensor.
Deep or contact (with fixing kit to the pipe) PT1000 temperature sensor (ø5x40 mm, 1 m length).

Return to the heating source (indicated by an orange arrow pointing left)

System return way (indicated by a blue arrow pointing left)

Supply bypass (Recycling) (indicated by a red arrow pointing down)

The piece is supplied with the clapet valve rod in stop position.
TAKE CARE

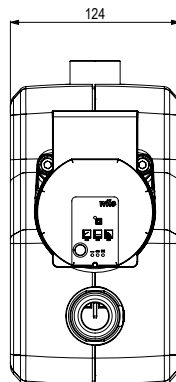
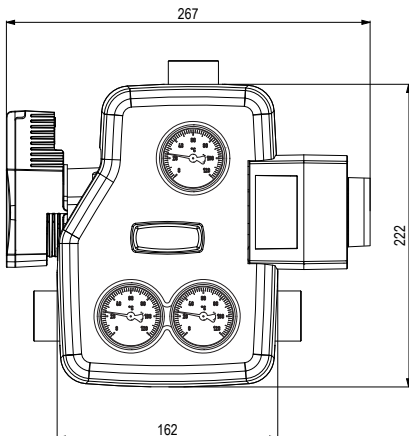

EPP insulation box. Measurements: 162 x 222 x 124 mm.

MCCS 3 - DN25 ANTI-CONDENSING RECYCLING PUMP UNIT

Overall dimensions and connections

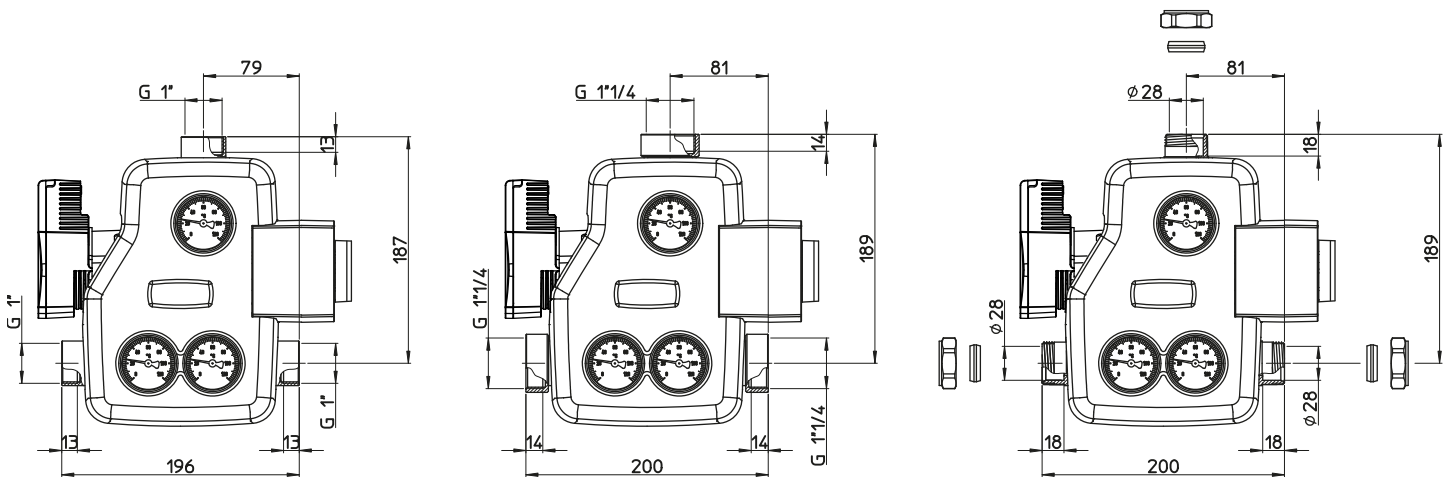

Sizes and dimensions of available connections

Technical features

Maximum working pressure:	10 bar
Maximum temperature:	100°C
Diverting temperature:	it can be selected from 10 up to 90°C

Field of utilization

- Direct supply to the distributor: up to 45 kW (with Δt 20 K) and maximum flow rate of 1950 l/h. Lifting power: 4 mH₂O
- With buffer tank: up to 90 kW (with Δt 30 K) and maximum flow rate of 2600 l/h. Lifting power: 2 mH₂O

External connections: 1" and 1"1/4 F, 28 mm for copper pipe.

Electrical connection



DANGER

The pump unit is fully pre-wired.
Use a Shuko plug to connect it to the electric system.
Voltage: 230 VAC \pm 10%.
Frequency: 50 \div 60 Hz.
Maximum absorbed power: 78 W

Employment

The anti-condensing pump unit allows to connect directly the solid fuel heating source to the heating system or to the buffer tank without any additional device.

As a matter of fact the pump unit includes into a compact and nice insulation box the circulating pump, the mixing valve with electronic control, the on/off natural circulation clapet valve, the isolating valves and thermometers. It automatically adjusts, to the selected value, the return water temperature to the heating source.

The device keeps the heating source at a high temperature level (always higher than the condensation one) in every possible condition of use, so avoiding deposits both into the boiler and into the chimney flue, in this way improving the efficiency and the life of it. Therefore also corrosion problems of the heating source or dangerous fires of the chimney are avoided.

Installation

The anti-condensing recycling pump unit can be placed on both sides of the heating source, following these directions:

- ✓ On the return pipe to the boiler in mixing mode, following the flow directions shown on the body.
- ✓ In vertical position (horizontal circulating pump axis) to allow the hydraulic working of the natural circulation clapet valve.

In order to optimize the anti-condensing control, we recommend the installation of the component on the return way to the boiler.

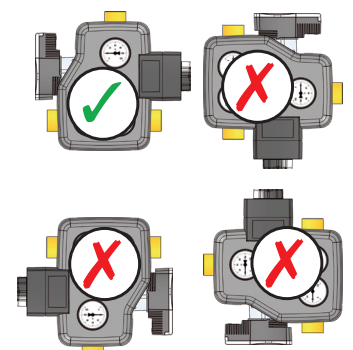

MCCS 3 - DN25 ANTI-CONDENSING RECYCLING PUMP UNIT

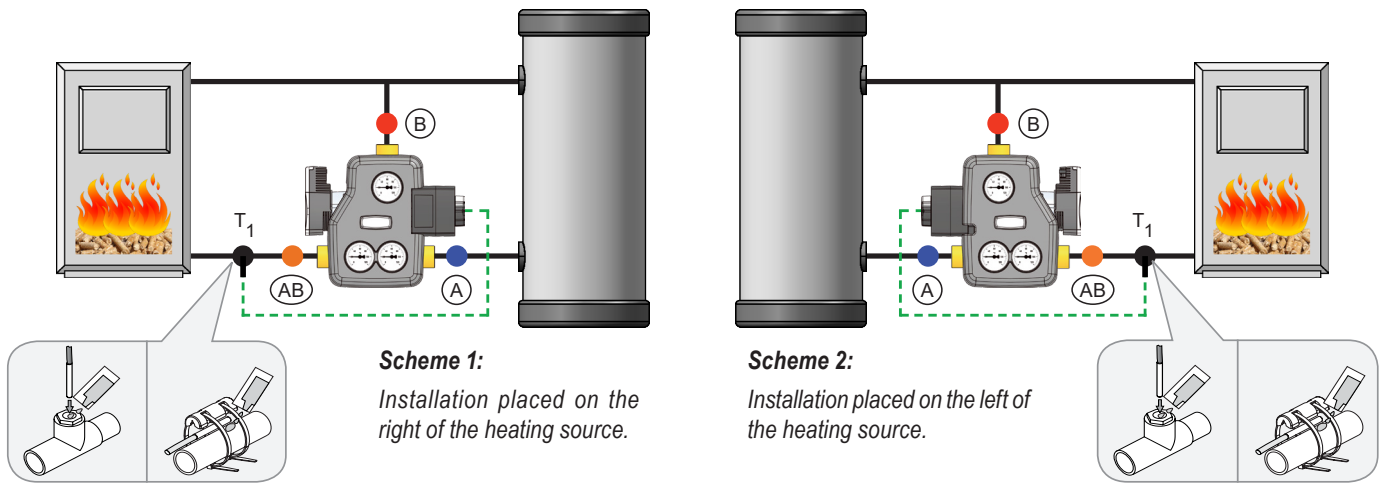

The standard model is set up for the installation on the right of the heat source (*scheme 1*).

To install it on the left (*scheme 2*) it is enough to put the three thermometers on the opposite side of the insulation box:

- ✓ Open the insulation box and remove the three thermometers from the seats;
 - ✓ Pierce the other half of the shell in the centre of the seat of the thermometer, the thickness is very thin and it is giving way easily;
 - ✓ Close again the two shells on the body and place the three thermometers into the holes previously prepared, taking care that they're placed into their seats on the brass body and that they're not protruding from the insulation box.
- Put the temperature sensor on the supply way towards the heat source, as indicated in the above schemes. It can be placed in contact with the pipe (by means of the supplied kit) or deep, using a special connection (not supplied).

Fixed temperature servomotor (ACD10)

The fixed temperature servomotor is already set and ready for use, with a set target temperature of 60°C.

Other working parameters are already preset at the most used values: if necessary it is possible to change them, *following the instructions on the servomotor instructions sheet*, to fit them to the values recommended by the boiler manufacturer.



Factory settings

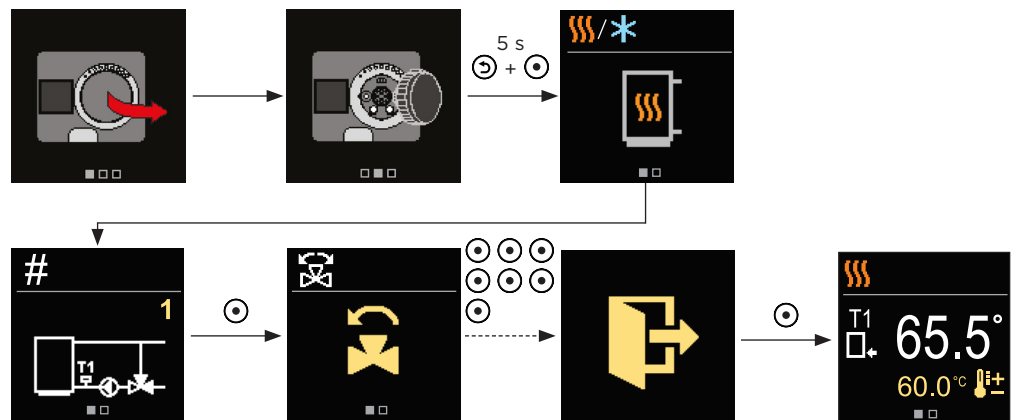
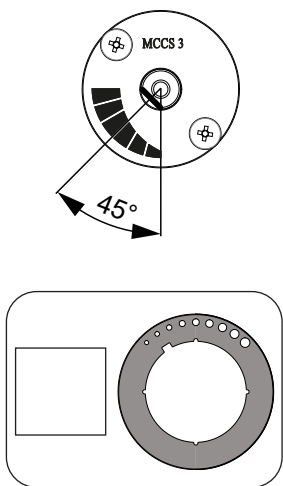

Model with 3 point servomotor (M21)

In this case the servomotor does not include the control software, that must be supplied from the outside by a controller or by the electronics of the heat source. In the scheme at side you can find the instructions to wire the servomotor.

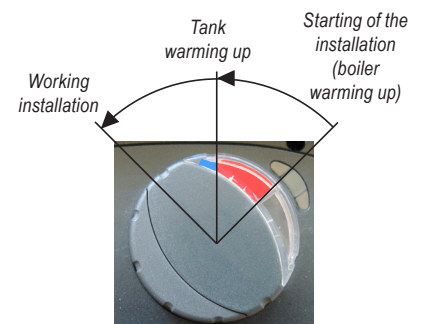
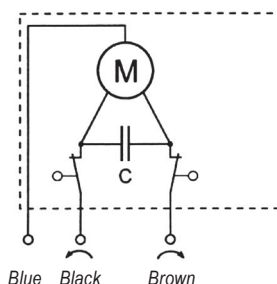

MCCS 3 - DN25 ANTI-CONDENSING RECYCLING PUMP UNIT

Working mode

The schemes shown below represent the different working phases of the anti-condensing pump unit.

Please note that: the pictures have to be considered just as an indication and they have no completeness pretention.

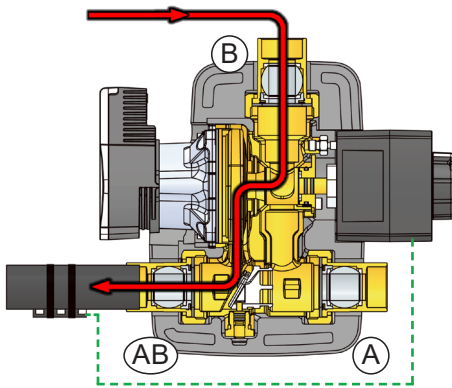

① Starting of the installation (boiler warming up)

After the starting of the boiler, the mixing valve is fully closed towards the system's return (**gate A**) and this condition remains until the fluid, warmed up by the heating source, gets the temperature set on the servomotor. During this step the fluid sent by the boiler fully recycles through the by-pass (**gate B**) and the boiler temperature rises very quickly.

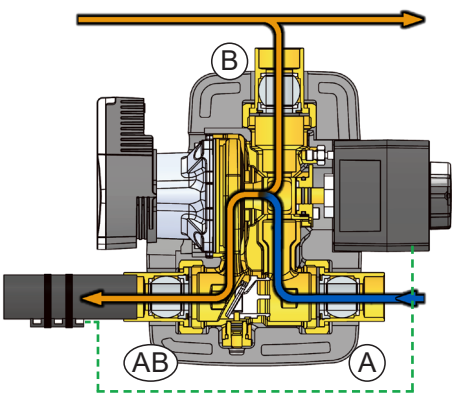

② Loading of the installation (tank warming up)

At the achievement of the diverting temperature (f.i. 60°C) the system's return way (**gate A**) proportionally starts to open, meanwhile the by-pass (**gate B**) is going to be closed. The boiler temperature slowly rises giving energy to the user, but in any case the return temperature will not decrease anymore below the diverting one (f.i. 60°C).

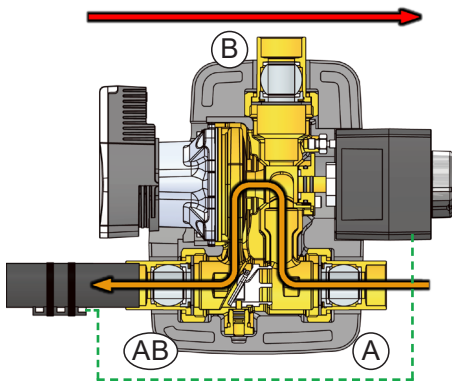

③ Working installation

Starting from the condition of point 2, the supply temperature progressively rises up to the full opening of the mixing valve (**gate A**) and up to the corresponding shutting of by-pass (**gate B**). It is possible to change the parameters of the servomotor to increase or decrease the reaction time from closed to open mixing valve, according to the features of the installation and to the power of the heat source. Now the installation is operative and the supply fluid temperature can increase up to the set value.

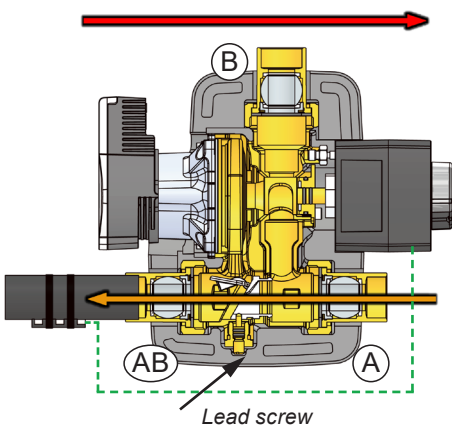

④ Natural circulation

The natural circulation of fluid through the clapet valve starts as soon as the circulating pump stops and the remaining energy of the heating source is transferred to the water tank. This function starts as a security device, when the pump stops due to blackout or failure, so avoiding that the temperature of the heating source can reach high levels of danger.



To turn on the natural circulation function please turn the control screw anti-clockwise. You can lock the clapet valve any time, turning the screw clockwise (this operation has to be done when the pump is working).

MCCS 3 - DN25 ANTI-CONDENSING RECYCLING PUMP UNIT

Synchrone high efficiency circulating pump Wilo Para STG

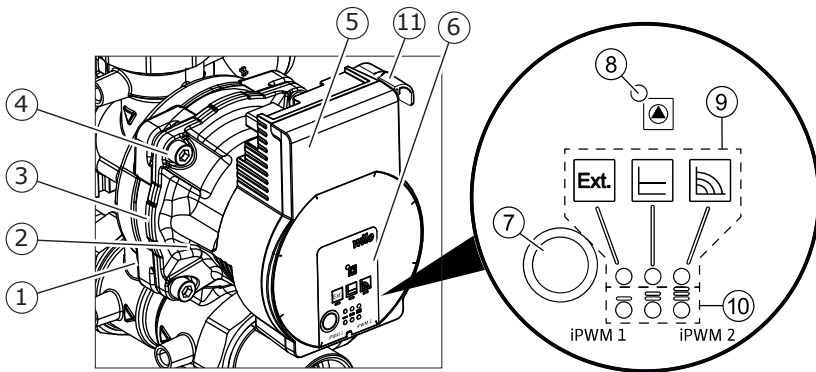

1. Pump housing with screwed connections
2. Glandless motor
3. Condensate drain openings (4x around circumference)
4. Housing screws
5. Control module
6. Rating plate
7. Operating button for pump adjustment
8. Run/fault signal LED
9. Display of selected control mode
10. Display of selected pump curve (I, II, III, PWM1, PWM2)
11. PWM signal cable connection

Indicator lights (LEDs)



- Signal display
- LED is lit up in green in normal operation
- LED lights up/flashes in case of fault

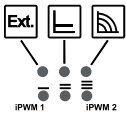

- Display of selected control mode: external control, Δp -c and constant speed
- Display of selected pump curve (I, II, III or PWM1, PWM2) within the control mode



- LED indicator combinations during pump venting function, manual restart and key lock

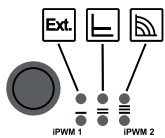

Press

- Select control mode
- Select pump curve (I, II, III or PWM1, PWM2) within the control mode

Press and hold

- Activate the pump venting function (press for 3 seconds)
- Activate manual restart (press for 5 seconds)
- Lock/unlock button (press for 8 seconds)

Control modes

- The LED selection of control modes and corresponding pump curves takes place in clockwise succession.
- Press the operating button briefly (approx. 1 second).
- LEDs display the set control mode and pump curve.

	LED display	Control mode	Pump curve
1		Constant speed	II
2		Constant speed	I
3		External control more iPWM	iPWM 1
4		External control more iPWM	iPWM 2

TAKE CARE

**RECOMMENDED
ADJUSTMENT MODE**

**NOT
RECOMMENDED
ADJUSTMENT MODE**

	LED display	Control mode	Pump curve
5		Constant differential pressure Δp -c	III
6		Constant differential pressure Δp -c	II
7		Constant differential pressure Δp -c	I
8		Constant speed	III

MCCS 3 - DN25 ANTI-CONDENSING RECYCLING PUMP UNIT



The Wilo Para STG circulating pump must be set in constant speed or external control adjustment mode. Constant differential pressure is not recommended in this application.

Hydraulic performances (A towards AB)

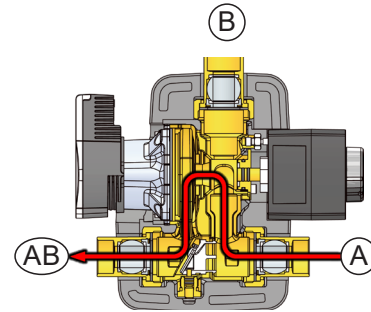
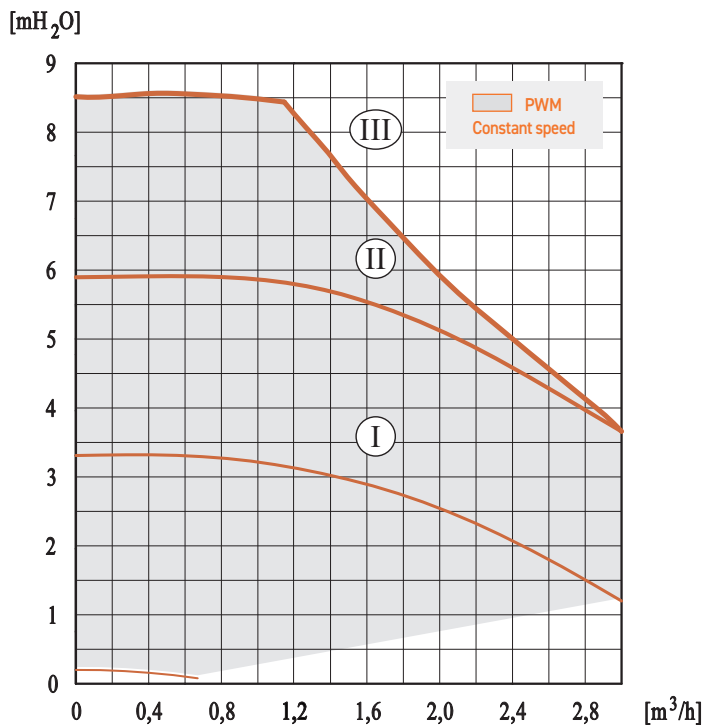

Synchronous circ. pump
Wilo Para STG/8
 Absorbed power: 10-75 W
Recommended adjustment mode:
PWM or constant speed

- Maximum speed (III)
- Medium speed (II)
- Minimum speed (I)



Pump factory setting:
Constant speed, pump curve III

Field of utilization

- Direct supply to the distributor: up to 45 kW (with Δt 20 K) and maximum flow rate of 1950 l/h. Lifting power: 4 mH_2O
- With buffer tank: up to 90 kW (with Δt 30 K) and maximum flow rate of 2600 l/h. Lifting power: 2 mH_2O

These performances are substantially the same even in case of recycling flow (B towards AB).