



Pump unit with climatic controller for one mixed heating system. The unit, by reading the outside temperature, sets the correct supply temperature of the plant on the basis of the set up climatic curve.

Wilo Yonos PICO 25/1-6 and Yonos PICO 25/1-8 circulating pump with built-in differential control: working with constant Δp or variable Δp .

① *Constant Δp* : for heating circuits with a stable pressure drop (f.i. underfloor heating) or plants (f.i. radiator heating) where the pressure drop of pipes is negligible in comparison with the pressure drop of the thermostatic radiator valves, or where independently from open thermostatic radiator valves, same differential pressure is requested.

② *Variable Δp* : in order to achieve the max energy saving and noise reduction. It is recommended in plants where the pressure drop of the pipes is higher than the pressure drops of the regulating valves, or more simply, when the requested differential pressure is decreasing when the flow comes down.

③ *Automatic air vent program*: turn the selector to this position at the first starting of the installation. The program, the duration of which is 10 minutes, starts the motor of the circulating pump alternately at low and high speed making the agglomeration of air bubbles towards the de-aeration points of the installation. Once the program is finished turn the selector to the preselect mode: Δp constant or Δp variable.

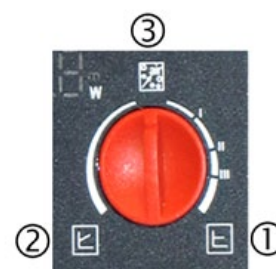

Typical curves of the pump units and of the circulating pump

energy consumption from 4 up to 40 W (Wilo Yonos PICO 25/1-6) and 4 up to 75 W (Yonos PICO 25/1-8)

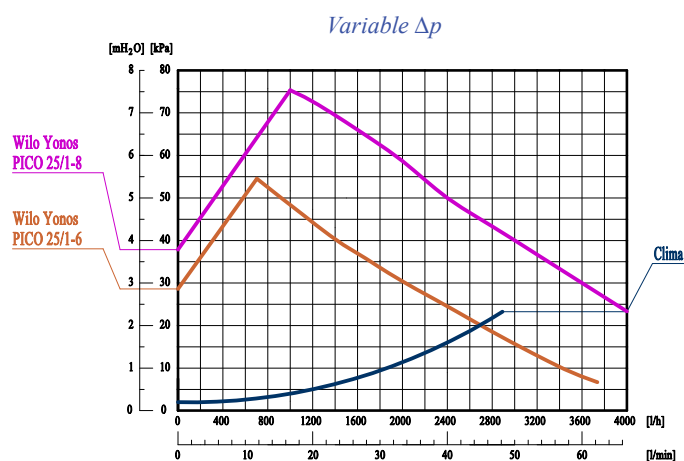
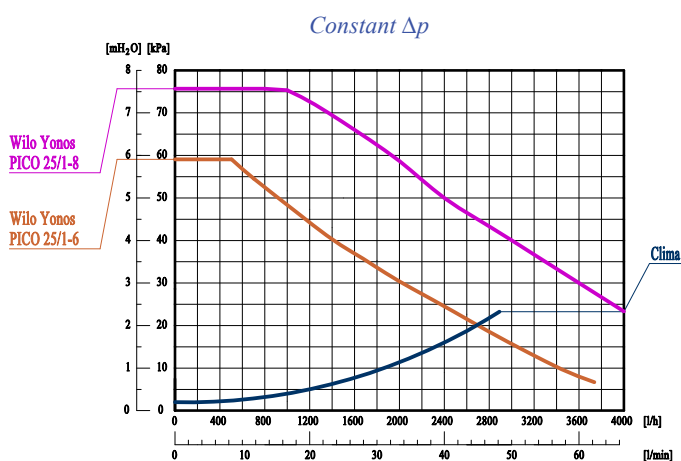

MIXING VALVE WITH SERVOMOTOR

3-way mixing valve with bi-directional servomotor with an operating range of 90°; led of activity in opening and closing mode. Selector for manual working with the indicator handwheel. A special connector allows to replace the servomotor in case of failure or bad working without having to operate on electric wires.

Kvs Value of the mixing valve: 10,0.

The model **M33** is supplied with a built-in by-pass into the body of the mixing valve. The built-in by-pass has an adjustable flow up to 50% of the total flow rate of the valve (especially suitable for underfloor heating installations).

Kvs Value of the mixing valve: 15,0.

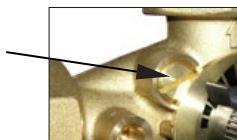

“CLIMA 3M” PUMP UNITS

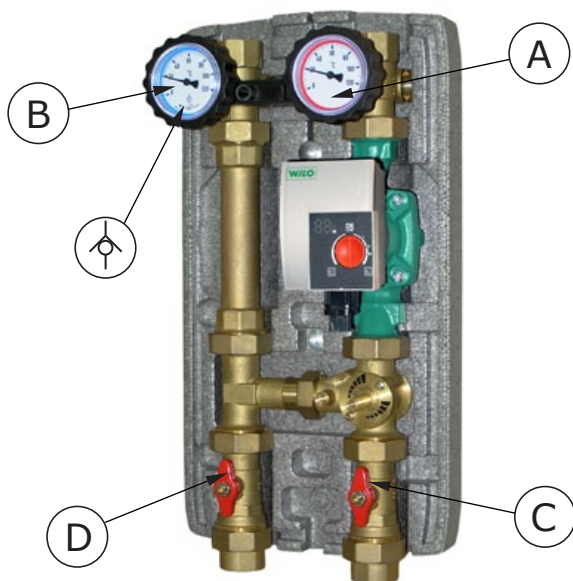

20 mbar CHECK VALVE

Always inside the return way ball valve (B), it prevents the natural circulation of the fluid (gravity circulation).



To prevent the natural circulation, the check valve must be in operating mode, that is when the ball valve is completely open.

The nick on the knob, near the temperature indication of 60°C, must be in axis with the return way.



To fill or to empty the installation, the Check Valve must be excluded, by rotating the handle by 45° clockwise, starting from the complete open position (see picture at left).

The nick on the knob, near the temperature indication of 60°C, must do a 45° angle with the return way.



To service the installation, the ball valve must be closed by rotating the handle by 90° clockwise.

The nick on the knob, near the temperature indication of 60°C, must do a 90° angle with the return way.

SERVICE

To service / replace the circulating pump or the mixing valve, close the ball valves (A), (B), (C) and (D) by rotating the handles clockwise. Once the service is finished, open the four ball valves and put again the installation under pressure.

FASTENING THE PUMP UNIT

If there is not a manifold, the pump unit can be fastened to the wall or to the storage tank thanks to a special back plate, as shown. EPP insulation box, measurements: 250x466x215 mm.

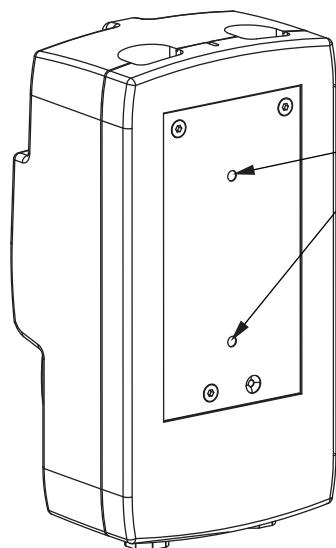

Back fixing holes on the plate suitable for M8 screws.

Special openings into the insulation box allow the fastening without dismantling the unit.

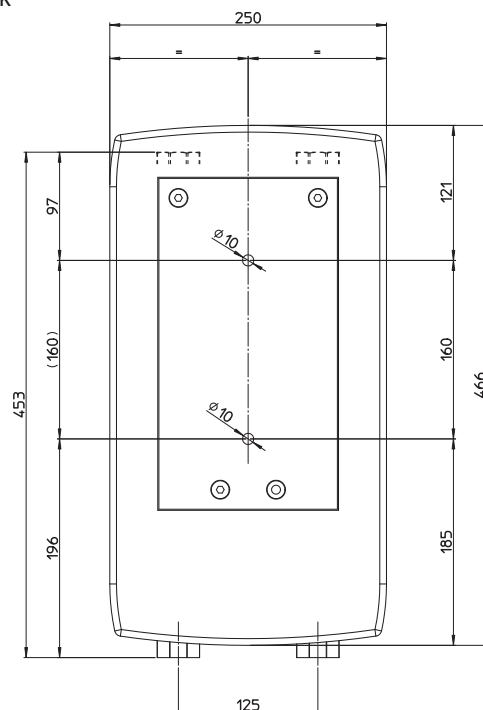
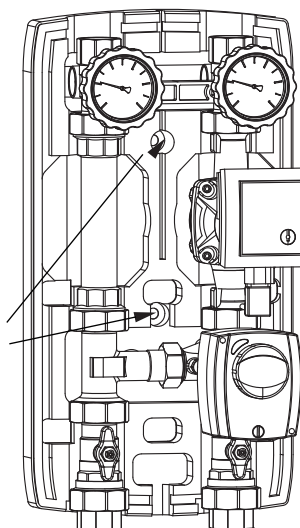

TECHNICAL FEATURES

PN 6, max temperature 110°C. (max. 40°C ambient temperature and 95°C fluid temperature).

External connections: 1" Female.

FIELD OF UTILIZATION

For power up to 35 kW (with Δt 20 K) and maximum flow of 1500 l/h.

Kvs value: 6,0. Approximate data calculated with a Wilo Yonos PICO 25/1-6 circulating pump (6 m nominal lifting power).

For power up to 20 kW (with Δt 8 K) and maximum flow of 2150 l/h.

Kvs value: 6,0. Approximate data calculated with a Wilo Yonos PICO 25/1-8 circulating pump (8 m nominal lifting power).

For an accurate measuring or higher flows, please refer to the curves of the circulating pumps, (constant Δp or variable Δp) shown in the first page.

CLIMATIC CONTROLLER “CLIMA 3M”

The climatic controller is supplied already pre-wired to the circulating pump, to the servomotor of the mixing valve and to the contact sensor S2 (TR/S1,5) of the supply mixed way. The power supply cable, also pre-wired, must be connected to the electric system 230 VAC only after having connected the temperature sensors.

To do these operations use only skilled workers.

Please install the controller following the here below directions:

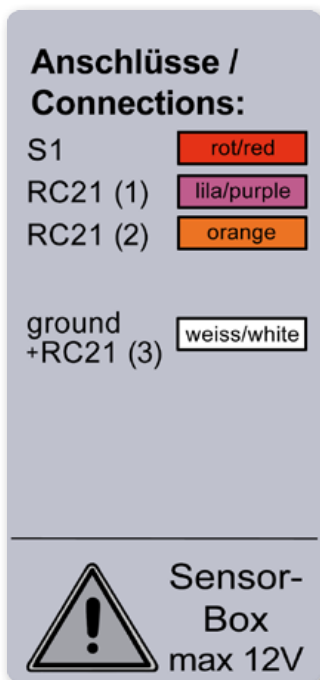

Picture 1: Connection of the sensors to the sensor box

✓ Connect temperature sensors (all are PT1000)

All the wirings must be done by means of the terminals inside the “sensor box”, in accordance with the scheme of the *picture 1*. The sensor box must be fixed to the wall near the pump unit.

S1: *outside temperature sensor TA52.* The wiring must be done by the installer by means of cables with a minimum diameter of 0,75 mm² and a maximum length of 30 m. For longer distances, the diameter of the cable must be increased and the resistance of the overall cable-sensor must be checked in accordance with the values shown in *table 1* (by connecting the wirings it is not necessary to respect the “polarity”).

RC21 (1): connect it to the terminal 1 of the room thermostat RC21 (*optional*).

RC21 (2): connect it to the terminal 2 of the room thermostat RC21 (*optional*).

RC21 (3): connect it to the terminal 3 of the room thermostat RC21 (*optional*).

ground: connect the second cable (white) of the S1 sensor to the multiple terminal.

Table 1: Resistance/temperature for wiring the sensors

°C	0	10	20	30	40	50	60	70	80	90	100
Ω	1000	1039	1077	1116	1155	1194	1232	1270	1308	1347	1385



Picture 2: Connection of the contact sensor to the supply way

✓ Connect the contact sensor TR/S1,5

Once the wiring of the sensors to the sensor box is finished, fix the contact sensor S2 (TR/S1,5) on the supply pipe after the ball valve with in-handle thermometer (coded red), by means of the clamp supplied as outfit, as shown in the *picture 2*. Moreover we recommend to put a thin layer of heat conductor paste between the sensor and the pipe.

Room thermostat RC21 (*optional*)

The use of the room thermostat allows the remote control of the system. In fact it is possible to manually counterbalance the supply temperature according to the requirements or, otherwise, to do it automatically in accordance to the room temperature, by putting in action the thermostat mode on the controller (look it up in its manual). *Selector of the function mode: automatic, day, night.*

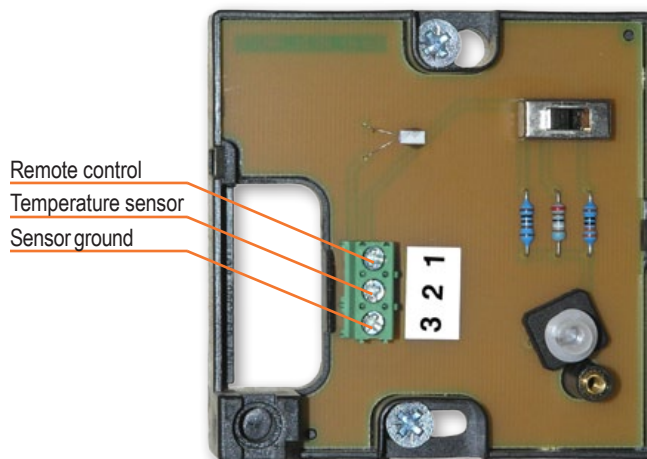

ATTENTION! When you connect the room thermostat it is necessary to keep away the white small cable that makes a bridge between the clamps RC21 (1) and RC21 (3) in the sensor box.

“CLIMA 3M” PUMP UNITS

HYDRAULIC SCHEME “CLIMA 3M”

✓ Mixed circuit

By means of this hydraulic scheme a mixed circuit can be controlled.

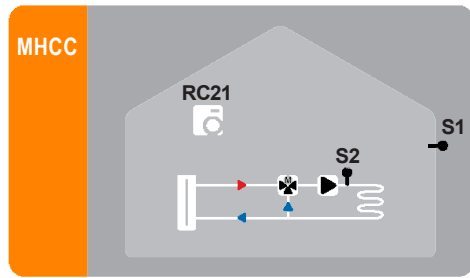

S1: outside temperature sensor TA52.

Attention: put the sensor always towards the north and anyhow far from any heat source.

S2: contact temperature sensor TR/S1,5 to be fixed to the supply pipe.

✓ Mixed circuit + boiler

With this hydraulic scheme it is possible to manage and to control the starting of the boiler by means of an output 0-10V or PWM when the temperature goes down under the value requested by the circuit.

If the boiler requires a zero-potential contact an outside relay (optional) must be connected

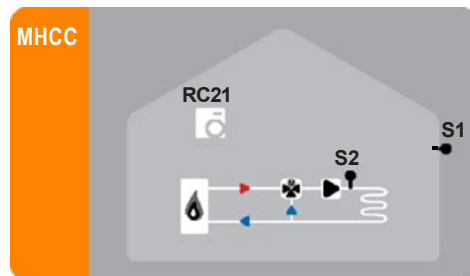

S1: TA52 outside temperature sensor.

Take care: place the sensor always towards the north direction and anyway far from any heat source.

S2: TR/S1,5 contact temperature sensor, to be placed on the supply pipe.

Boiler contact: connect the boiler to the V1 clamp (0-10V signal) shown in Picture 3.

To do this connection you must open the electronic controller by means of the central screw to remove the cover (please refer to the controller manual).

To transform the signal from 0-10V into a zero-potential contact usually open or closed, use an outside optional relay.

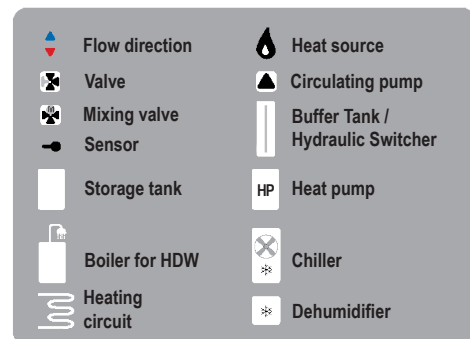

Outside optional relay

CLIMA 3M connection terminal board



ATTENTION!

The above indicated pictures must be used only as an indication of the different hydraulic systems, therefore they do not claim to be complete.



ATTENTION:

The left side of the connection terminal is usable only at low voltage (f.i. 12 VAC/DC)



DANGER:

The right side of the connection terminal is usable only for 230 VAC 50-60 Hz voltage electrical supply

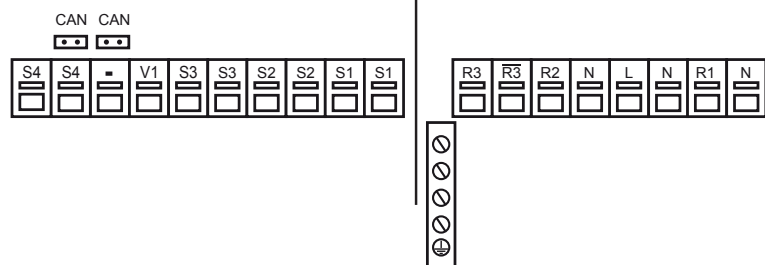

Pict 3: Connection terminal of the climatic controller