

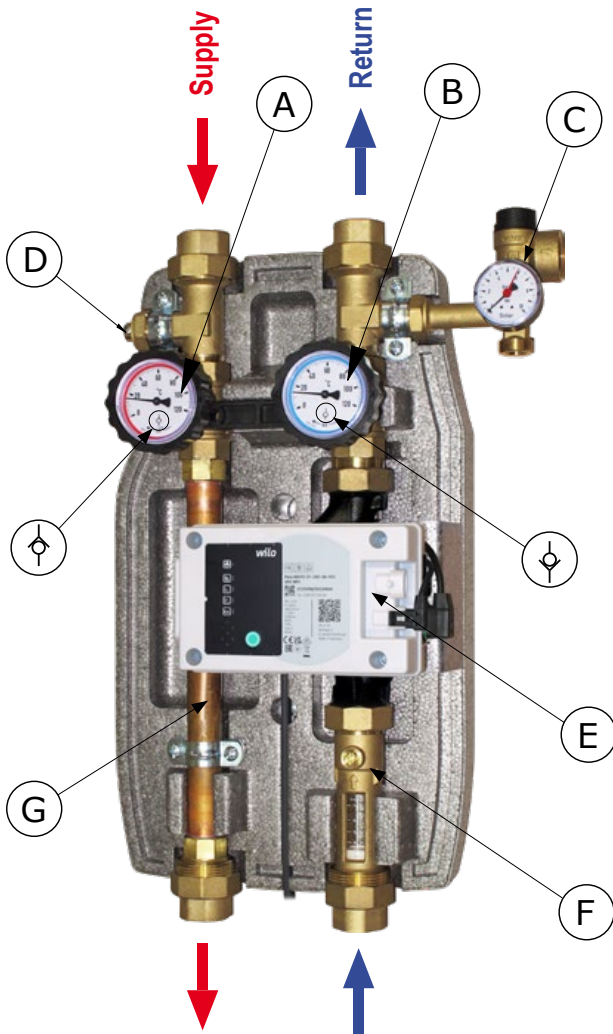

SAFETY: Please read carefully the mounting and the setting working instructions before starting the unit, in order to avoid accidents and failures caused by an incorrect use of the product. Please keep this manual for future consultations.



DIMENSIONS

EPP Insulation box: Side opening on the base for the safety group. A dedicated opening allows to read the flow rate without removing the lid. Dimensions: 285x500x170 mm. A special metal back plate fasten the unit to the insulation and allows easy installation both on the wall and on the storage tank.

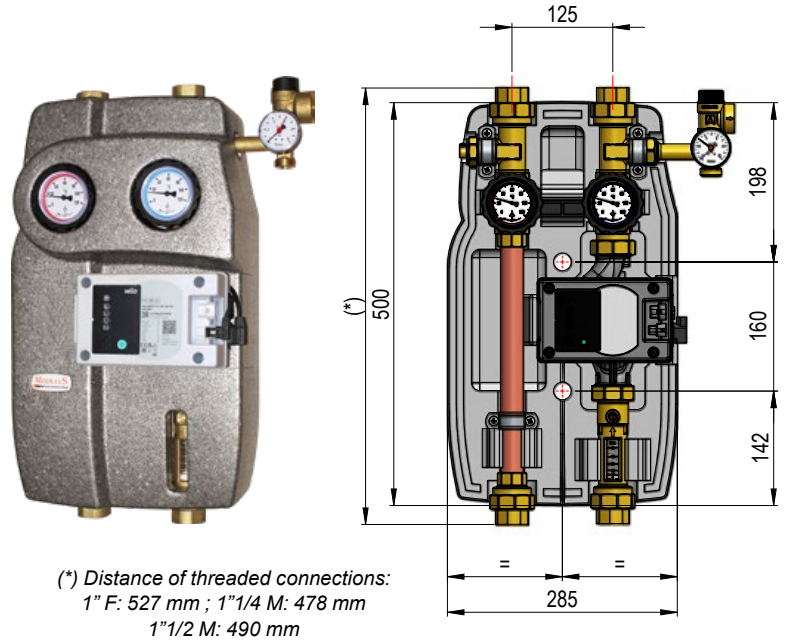

MAIN COMPONENTS

- A. Supply ball valve provided with 18 mbar check valve which can be excluded, supplied with in-handle red ring thermometer, range 0-120°C.
- B. Return ball valve provided with 18 mbar check valve which can be excluded, supplied with in-handle blue ring thermometer, range 0-120°C.
- C. 6 bar safety unit with 0-10 bar pressure gauge with connection to the flexible hose of expansion vessel (not included).
- D. "T" connection with $\varnothing 6$ mm sensor holder pit.
- E. Synchronous high efficiency circulating pump externally controlled by 0-10V signal.
- F. Flowmeter with flow regulation.
- G. Supply connection pipe.

MAINTENANCE

To operate an incidental service/replacement of the circulating pump, close the ball valve (B) and regulation rod (F) by rotating clockwise. Once maintenance is over, open again the two ball valves and restore the pressure of the system.

CONFORMITY DECLARATIONS / QUALITY DECLARATIONS

Solar pump units series is manufactured according to the Quality System certified ISO 9001:2015, ICIM / IQNET

SOLAR PUMPING STATION S2 SOLAR 2 HIGH FLOW

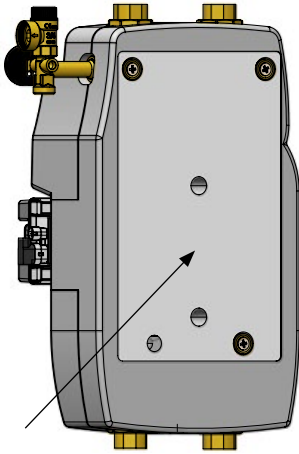

Metal back plate to fasten the unit to a wall or to a water tank.

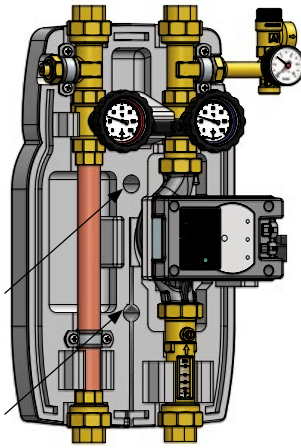

ø10 fastening holes on the back plate. Special passages on the insulation allow fastening without having to disassemble the unit.

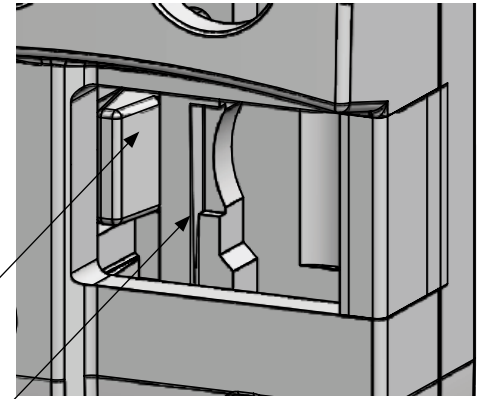

Due to high temperature of the supply pipe, the insulation box is provided with a separation wall to avoid the contact of the pipe with the wirings of the circulating pump. Moreover the cables must be placed into the special groove of the base of the insulation box.

TECHNICAL FEATURES

PN 10. Constant temperature 120°C;
(short time temperature: 160°C for 20 s).

Working fluids:
water (max glycole 50%)

MATERIALS

- Fittings and components: copper alloy CW617N
- Insulation: PPE
- Flat gaskets: EPDM peroxid

FIELD OF USE

For power up to 100 kW.

DIMENSIONS

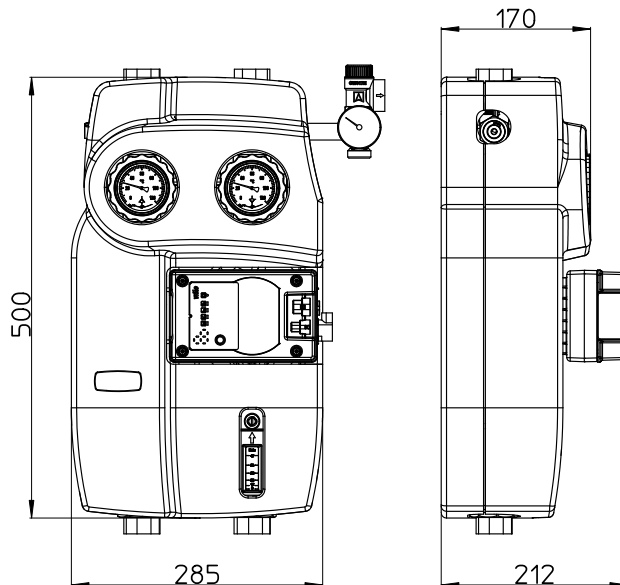
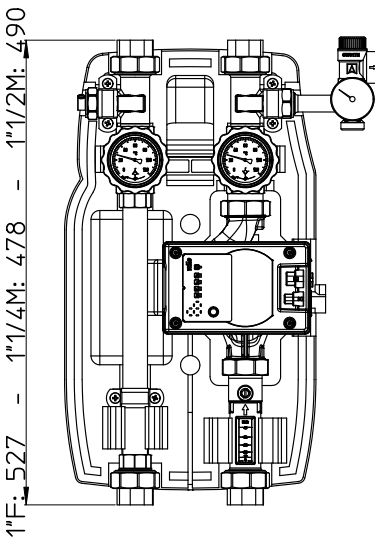
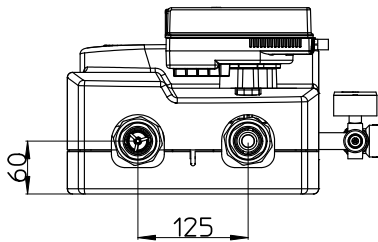

SOLAR PUMPING STATION S2 SOLAR 2 HIGH FLOW

CIRCULATING PUMP



The synchronous Wilo Para Maxo circulating pump needs a PWM or 0-10V controller.

The Wilo Para Maxo circulating pump is a high efficiency pump and the regulation of the revolutions must be operated by digital PWM signal or analogic signal 0-10V. Therefore it is

This model of circulating pump controls automatically the flow: therefore it is not necessary to set it manually. It is recommended to keep the flowmeter fully open.

Lenght	Connection	Supported control modes	Power consumpt.	I max	PN	Temp. range	Electrical connection	EEl
180 mm	2"	PWM / 0-10V	5-128 W	0,91 A	PN10	-10 ÷ 110°C	230 VAC, 50/60 Hz	≤ 0.20

PERFORMANCE CURVES OF THE SOLAR PUMPING STATION AND CIRCULATING PUMP

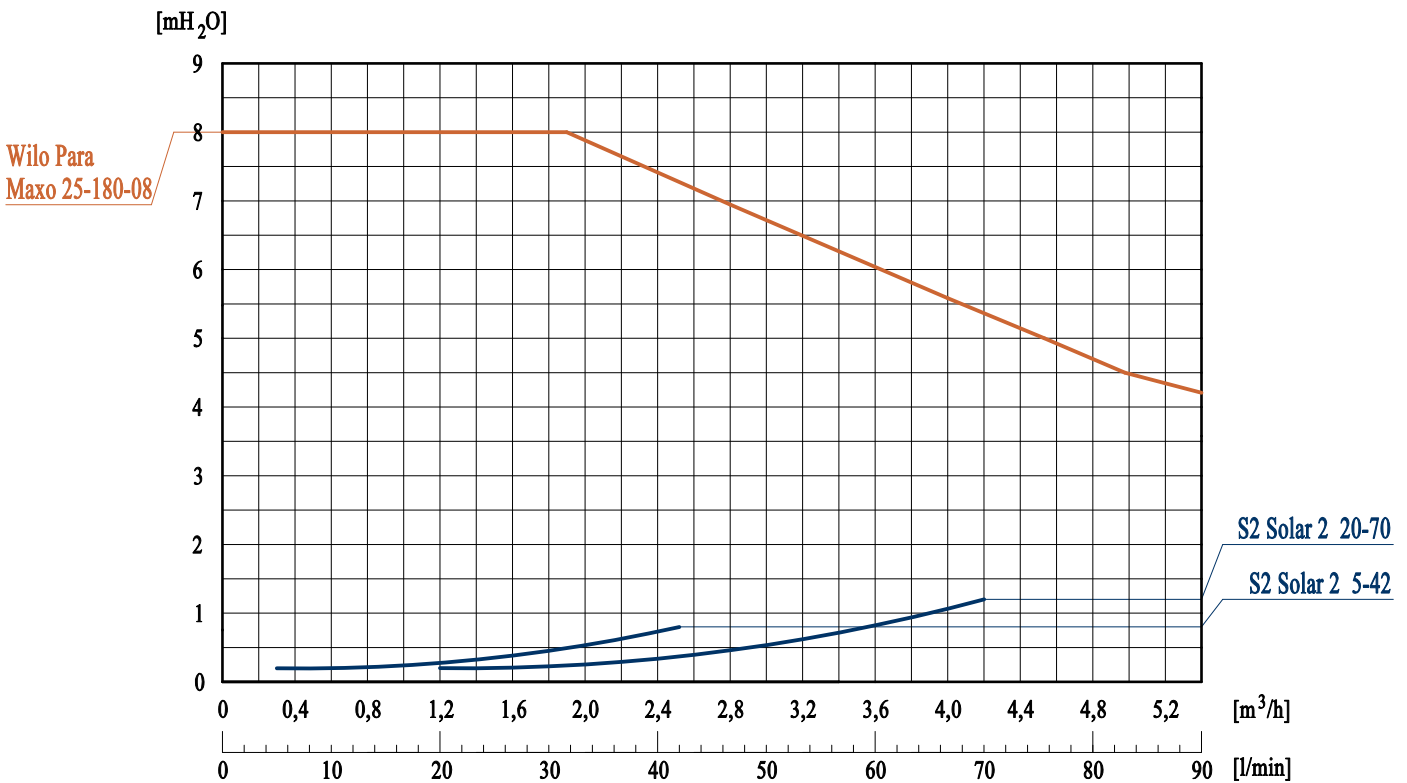

ATTENTION

ELECTRIC WIRING

Connection to the electric system: Voltage: 230 VAC ± 10%.
Please be sure that the electric wirings are made only by an electrician in conformity with the local directions in force. The type of current and the tension must correspond to the directions written on the data plate of the circulating pump.



SAFETY: Temperatures reached by the fluid can be high enough to cause scalds and burns. The unit must be installed by a qualified installer. After the installation, check the tightness of the connections to avoid leaks during working operations.

SOLAR PUMPING STATION S2 SOLAR 2 HIGH FLOW

COMPONENTS AND OPERATION

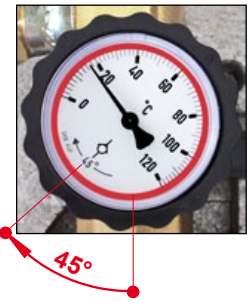

18 mbar check valve

“Solar” check valve built-in in the ball valve, both in the supply and in the return way. It guarantees tightness and low pressure drops. To exclude the check valve, for example in case of draining the system, turn the handle 45° clockwise.



Safety unit

The safety unit, CE and TÜV approved, protects the installation from overpressures. It is calibrated at 6 bar and over this pressure the unit intervenes. It is also provided with a $\varnothing 50$ mm 0-10 bar pressure gauge and with a connection to the expansion vessel by means of a 3/4" flexible kit (optional).



Flowmeter regulator

The flowmeter allows to read the flow rate as well as to fill easily the system. The flow rate is shown by the special sliding cursor. Two flowmeters are available with different intervals of measurement: 5-42 L/min and 20-70 L/min. The flowmeter regulator, and therefore the pumping unit, must be mounted only vertically.

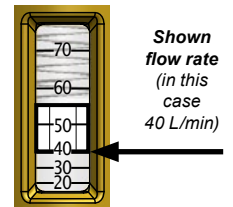

Shown flow rate (in this case 40 L/min)

The flow rate is shown taking as reference the lower edge of the sliding cursor.

The integrated ball valve also allows fine adjustment of the system flow rate. However, it is recommended and preferable to adjust the flow rate by controlling the high efficiency synchronous circulating pump.

FILLING THE SYSTEM - Filling/Draing ball valve (optional)

Attention: filling/draing ball valve (optional) to be connected on site on the return branch before the solar pumping station.

1. Check the connections to the circuit and to the expansion vessel;
2. Make sure that the ball valves (A), (B), (F) are open;

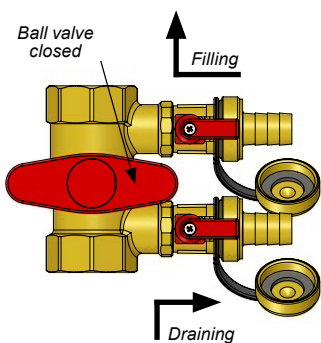

3. Remove the plugs from the side valves and connect the hose unions, by connecting them to the filling device of the system;
4. Close the flowmeter ball valve and open the side filling and draining valves;
5. Fill the system up to a pressure level set by the project;

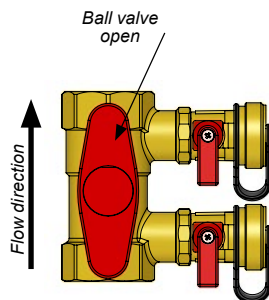

6. Close side valves, remove hose unions and re-screw plugs;
7. To avoid any accidental opening of the side taps it is advisable to block the levers in the closed position as illustrated alongside;
8. Reopen the ball valves;

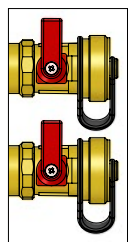

Blocking the filling/draing levers: unscrew the fixing screw, take out the lever and place it again turning it by 180°.

9. Start the circulating pump and check that there are no leaks from the connections;
10. After a few minutes of circulation, deaerate the circuit;
11. Adjust the flow rate of the circuit, preferably by acting on the control of the high efficiency synchronous circulating pump, alternatively carry out the adjustment by acting on the ball valve of the flow meter, until the desired flow rate is read on the indicator;
12. After a few hours of operation, check again the system pressure, the tightness of the connections and repeat deaeration.