

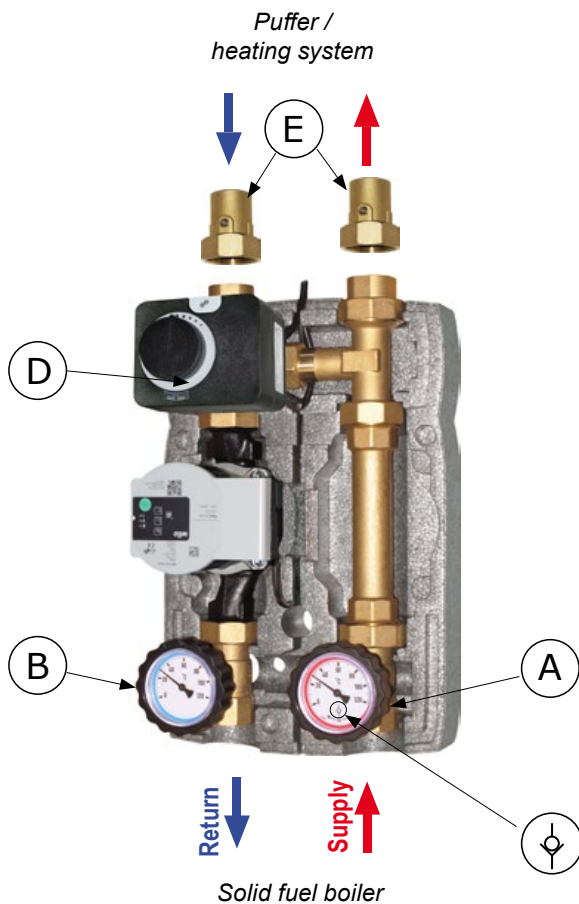

Installation instructions



Note: A group with supply to the right is shown

SERVICE

We recommend you to install two isolation ball valves (E) (optional) before the pump unit to allow an easy service or replacement of the pump unit components. In this case close the valves (A), (B) and (E) by rotating the relevant controls clockwise. Once the service is over, open again the valves and restore the pressure of the installation.

TECHNICAL FEATURES

PN 10. Maximum temperature 110°C (calculated with pump unit without circulating pump).

Available external connections: 1" F

SERVOMOTOR

3 points servomotor for mixing valve. Bidirectional, reversible with fixed limit switch for an operating range of 90°. 2 min., torque: 5 Nm. Power supply 230V. IP42. **An electronic external controller is required.**



DIMENSIONS

EPP insulation box: the insulation covering includes a central inside part that hugs the circulating pump and that allows the passage of the cable of the circulating pump. Outlets for the passage of the cables towards the upper part and the lower part of the insulation box. **Dimensions: 250x380x170 mm.**

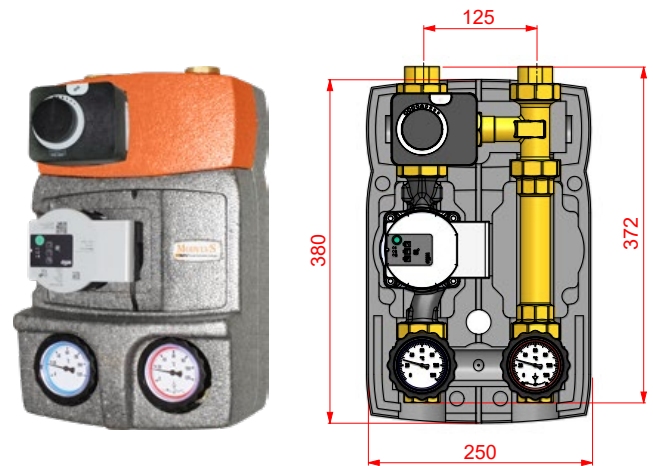

20 mbar CHECK VALVE

It is always inside the ball valve (A) of the supply way, it prevents the natural circulation of the fluid (thermosiphon effect). The check valve can be excluded by rotating the handle by 45° clockwise from the opening position.



FIELD OF USE

For power up to 50 kW (with Δt 20 K) and maximum flow of 2150 l/h. Kvs value: 6.0.

Approximate data calculated with a 6 m head circulating pump. For an accurate measuring or higher flows, please refer to the curve of the circulating pump.



Read carefully the servomotor instruction sheet, included in the package with this manual.



The electrical connections have to be done only by an electrician, in compliance with the local regulations in force.

M2 MIX3 CS M21D ANTI-CONDENSING PUMP UNITS - DN25 SERIES

INVERSION OF THE PUMP UNIT. LEFT SUPPLY.

All M2 MIX3 CS pump units can be inverted to change the supply way from right side (the most popular execution) to the left side.

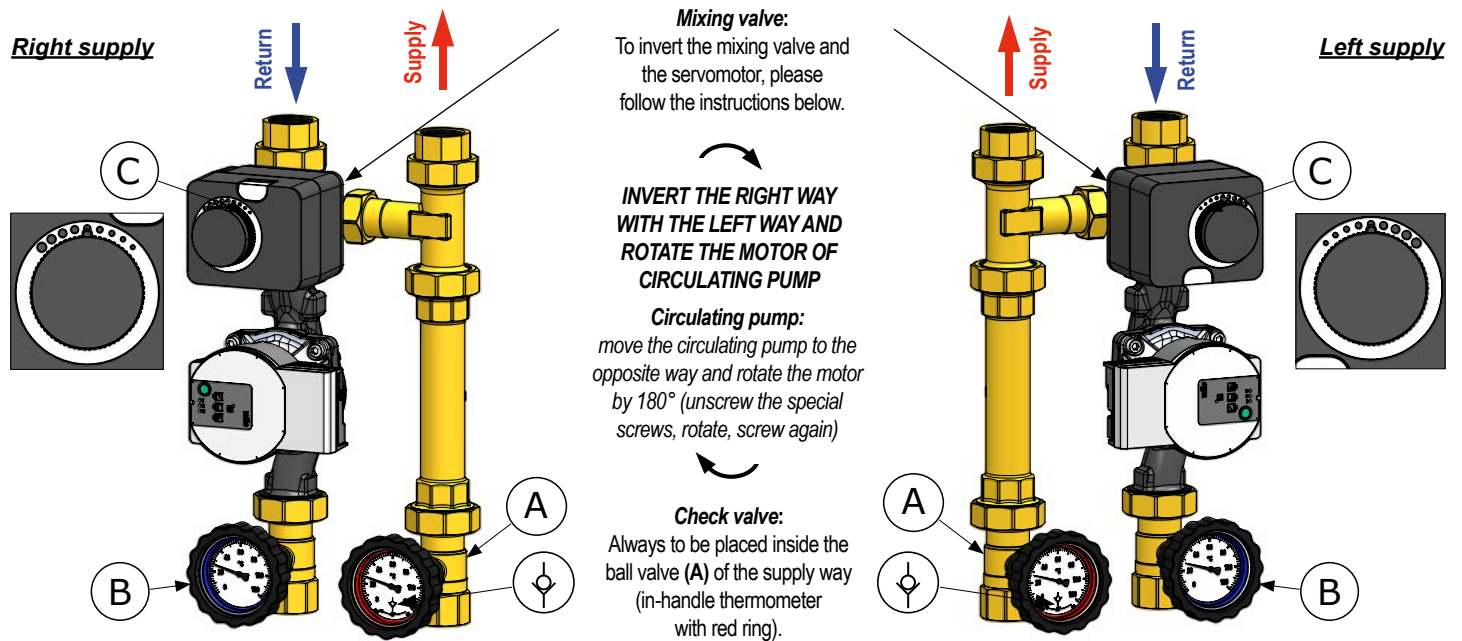

INSTRUCTIONS TO INVERT THE MIXING VALVE

Inversion of the mixing valve from right to left supply. Please follow the directions:

1. Remove the servomotor
2. Remove the fixing screws of the rod plug and of the back plug; then take out the components as shown in the illustration
3. Mount again the components in the inverted position, following the illustrations and make sure to match the reliefs on the body (A) with the respective seats (B) for both plugs. Screw again the four fixing screws.
4. Place the knob indicator on the scale "VL links" for the left supply, or "VL rechts" for the right supply.
5. Reassemble the servomotor.
6. Move the return temperature sensor, keeping it on the cold pipe.

